

PROJECT 4: COMPANY STYLE GUIDE

Utilize your company logo created in Ex 3, the design and folded dummy from Ex 8, your page layout from Ex 9 (or you can choose to start over), and information acquired about your company to create a style guide.

Research other style guides for typical content for the type of company you have chosen. Acquire small books for inspiration on size, layout and use of typography. Utilize design books and magazines as resources. Review the StyleGuide presentation.

SPECIFICATIONS:

Using InDesign or QuarkXPress create a minimum of an 8-page signature, or alternatively a 16-page signature and a separate cover.

Size can be of your choice, but it is suggested that you make it printable on 11" x 17" tabloid size paper when set-up as spreads (see below). I would suggest a document no smaller than 5" in spreads or no larger than 8" spreads to enable you to output onto a 11" x 17" tabloid sheet.

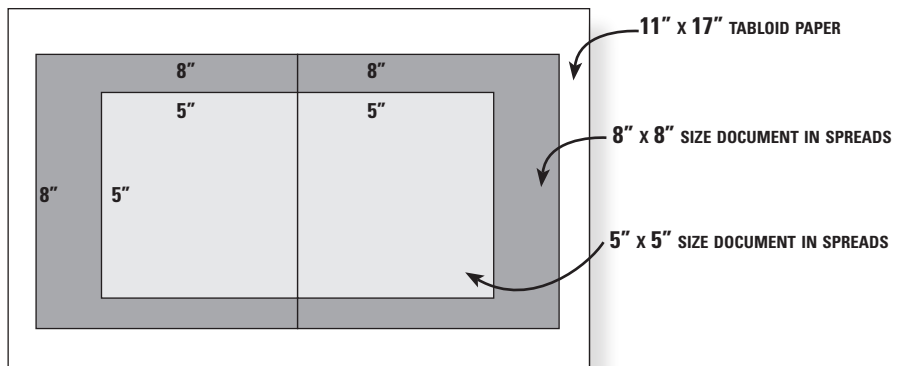

PRESENTATION AND CRITIQUE:

Your project should be printed and imposed pages, folded, assembled, with the cover saddle stitched (East lab as a special saddle stitch stapler for use— see lab assistants) or alternative approved binding method, and trimmed to finished size. Booklet will be graded on correct imposition, and neatness of assembly. For Critique, print a copy of your creative brief for this project that should include a minimum of the following topics and utilize this brief during presentation.

Creative Brief:

Your Name

Company Name

Brief company description including services and/or products

Audience for your style guide

Concept description: this should be in terms that describe the "look" of your company - something that has continued throughout the pieces you have designed for the company (past projects). Examples might be— "contemporary," "retro," "feminine," "alternative," "urban," etc. It may take a few words, but should be simple.

Why it is you chose this design

Creative research utilized, Influence/design strategy

Contents of the guide

Fonts you chose to use and why

Images utilized

Any optional choices used, such as size, die cut, alternative binding, etc.

Add at critique and use names: Minimum of one comment made during critique that you found beneficial and a minimum of one comment you made during critique about someone else's presentation.

FOLDER AND FILES FOR DROP:

Utilizing good design principles and technically correct production specifications to create this booklet. Save the files in a folder named your LastName, FirstInitial P4. Name files appropriately so they are recognizable in a name of your choice. Do a Collect for Output/Package so that all files utilized in layout are provided.

Upon completion and on the due date/time put a copy of your folder with required files in your Instructor's Drop-box. If any portion of the project is late – files not ready and dated before due date or mounted for presentation/critique – the entire project will be regarded and as late.

GRADING CONSIDERATIONS:

| | | |
|------------------|---|----|
| Creative Process | Creative Brief, utilization of research and creative resources | 5 |
| Design/Content | Appropriate design solution for goal Application of good design principles including typography– hierarchy, balance, flow, use of elements, unity and creativity Appropriate choice of imagery/text Content complete Ex 9 refined and improved | 40 |
| Software | Setup, document color mode, bleed (if used) format and color space of images used correct placement of images and required elements Text complete and formatted correctly | 30 |
| Critique | Appropriate support and verbal explanation of concept / methods | 5 |
| Presentation | Neatness of assembled booklet Appropriate materials used and correct assembly Professional presentation mock up Printed creative brief with critique notes added | 10 |
| Files | Folder / file names and extensions, supporting files collected/packaged included | 10 |
| Late deduction | 10 points deduction if accepted | |

REPOSITIONING AND PRINTING PAGES IN PRINTER'S SPREADS:

You should have used facing pages for the layout of your booklet. If so, you will have designed the booklet in what are referred to as reader's spreads. For the purpose of printing in the correct order to create your booklet, you will need to create printer's spreads. This will allow you to glue whole spreads back to back, collate, and saddle stitch into a booklet.

Make sure you are completely finished with your layout before beginning this and Saved a final time. If you make a mistake but have saved right before doing this you can Revert to Saved from the File menu.

Important Notes!

You can not Undo deleting pages in either InDesign or Quark so it's important to save a copy before beginning this action.

Be certain you have selected a Printer that can print two of your pages side by side with trim and registration marks, including the bleed area if you have one.

When ready to print, if you are unsure that your settings for spread are correct, print the entire document to a PDF for digital proofing before hand. Check the PDF to see if the spreads are correct then send the job to the printer.

Also, it is suggested that you print the cover page/pages on heavier or a different paper to distinguish it. If that is not possible you could glue extra layers to create the weight.

Using InDesign

- Once layout is complete, choose File > InBooklet SE.
- In resulting window:
 - Under "Layout" choose: Pages: All, Style: 2-up Saddle Stitch
 - Under "Printing" choose: Spreads: All, Printer's Marks: Check all
 - Under "Preview": Make sure the layout looks correct. You may wish to create a separate document for the spread layout. If so, check the "Create New Document" option in the bottom left corner and click "Print", otherwise leave unchecked and click "Print."
- In the resulting print window check all options to be sure the layout is centered and the paper size and orientation (horizontal) is correct. InBooklet will have created spreads and included all marks (if set correctly) for you, so you do not have to set these options again in the print window.
- Check with the Lab Assistants for your printed pages. If you have an 8-page layout your print should result in 4 pages total. If you have a 16 page layout your print should result in 8 pages total. You will need to mount the correct corresponding pages back to back of each other, collate correctly, saddle stitch, fold and trim to finished size.

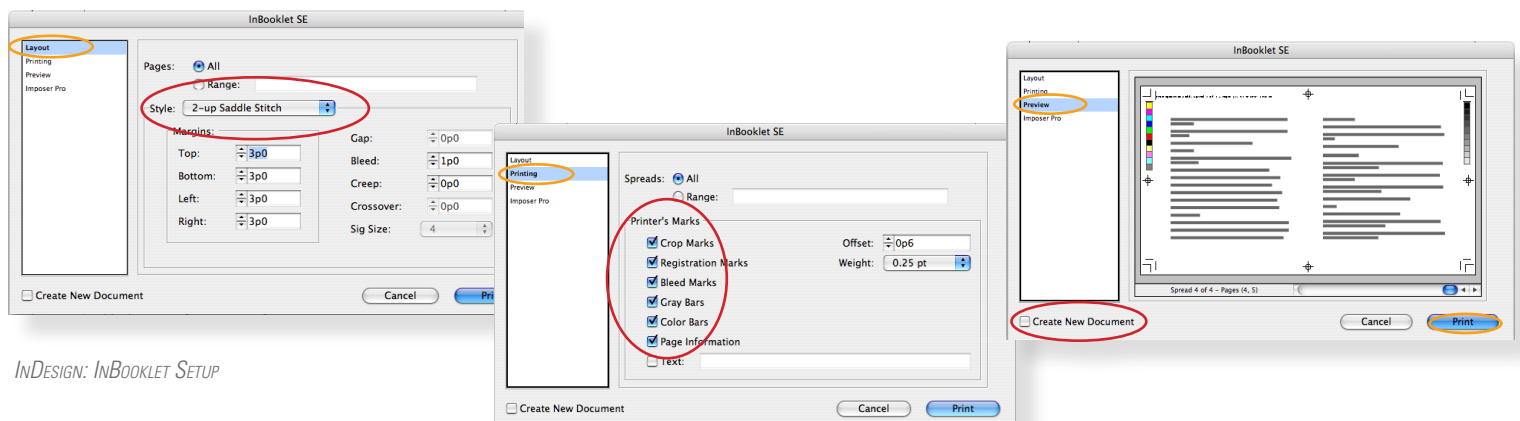

Using QuarkXPress

- Once complete - in the Page Layout palette double click page 2. From the menu choose Page > Section > Section Start : Page 2. You will see an asterisk appear next to page 2 in the palette.
- Double click Page 1 in the palette, it should still have an asterisk next to it. If not, with Page 1 highlighted, choose Page > Section > Section Start : type 1. Once both Page 1 and Page 2 each have their own asterisk, drag Page 1 down in the Page Layout Palette so that it is to the right of page 8 (or 16). You now have only 2 page spreads - no single pages.
- From the File> Print dialogue box, Under Layout, Select Spreads and Registration centered.
- From the Set up area select the correct printer description and paper size and direction - in most cases horizontal. Page Positioning should be centered.

QUARKXPRESS SECTION START
AND IMPAGINATION:

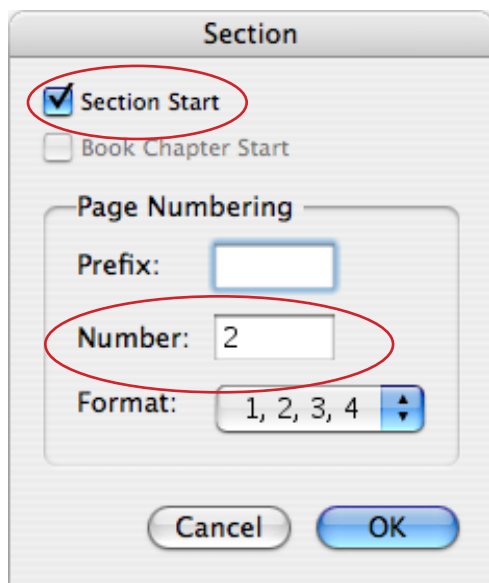

- You should not need to change Output, Options, Layers or OPI. If you have a Bleed, type in at least .125" as the bleed amount.
- Check the Preview area to see if your set up looks OK. Consider test printing to a PDF document for proofing. When ready print all pages, glues corresponding pages together, collate, saddle stitch, fold and trim to final size.

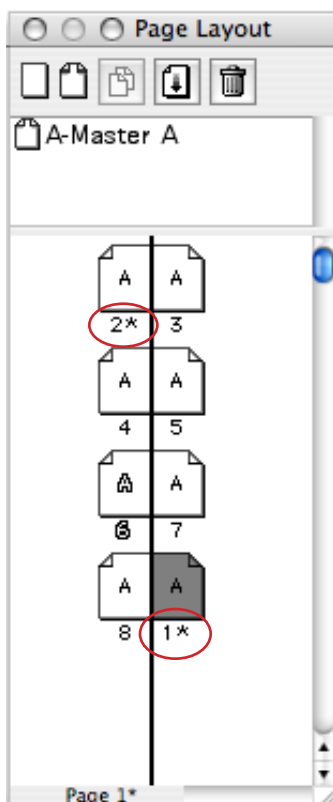
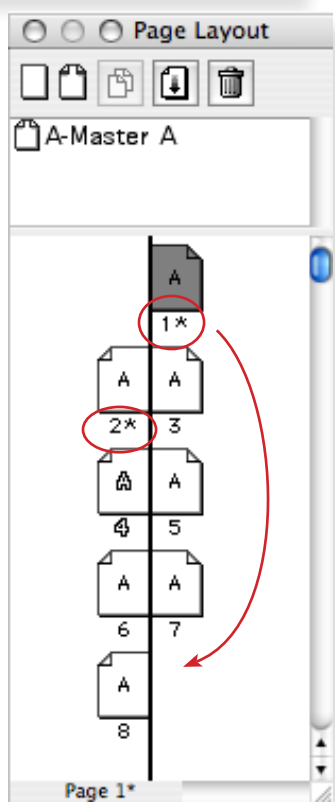

ASSEMBLING THE BOOKLET:

Once you have all pages proofed and the final versions printed you will need to assemble your pages.

- Refer to your folded dummy to back up pages correctly. If spreads are assembled correctly page 8 and 1 will back up to 2 and 7. You will end up with 4 back to front inside spreads creating the 8 inside pages. (this will differ if you have laid out a 16-page booklet)
- When pages are complete and glued: position and align carefully then staple along the center fold. Staples should be from the outside pointing inward. Trim off excess along all sides except fold.

